

DRAWING AT FULL SCALE, PLOT AT 0.375=1!!!

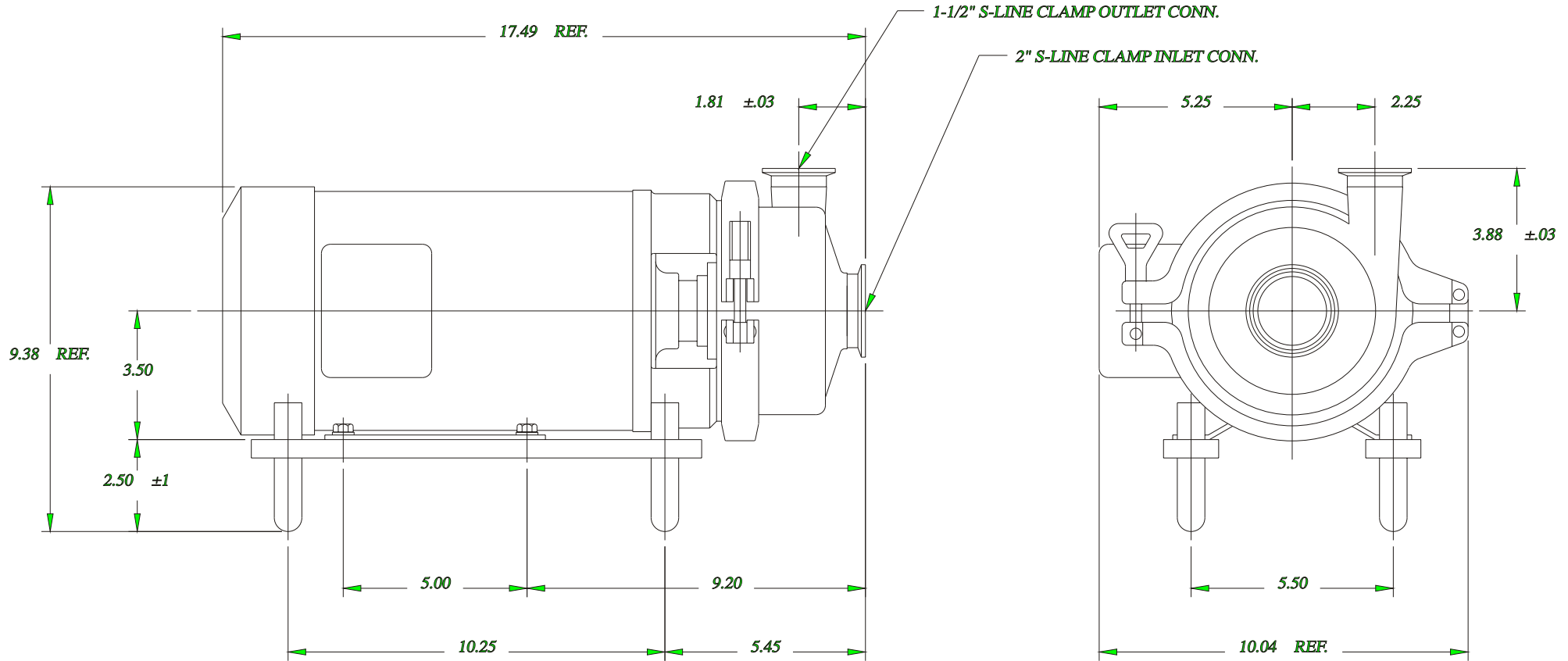

MOTOR SPECIFICATIONS:
 BALDOR - TEFC
 3 PHASE 60 HZ 230/460 VOLTS
 2 HP @ 3500 RPM
 145JM FRAME

PUMP SPECIFICATIONS:
 2045-2015-MP PUMP
 4.50" DIA. IMPELLER
 TYPE 1 SINGLE MECHANICAL SEAL
 CARBON ROTARY/PUREBIDE STATIONARY
 VITON ELASTOMERS
 ADJUSTABLE LEG KIT

RELEASE

2015-145
 CENTRIFUGAL PUMP LAYOUT
 2045-2015-MP 145JM MOTOR

- 1 1
 TDB
 8-12-98 B 0