

## Gerstenberg Schröder Hot Water Unit

### GS Hot Water Unit Benefits:

#### ALL IN ONE

The GS hot water unit (HW unit) is a compact modular skid unit which supplies hot water at up to four different temperatures for various processes. The main GS HW unit consists of one plate heat exchanger and one water circulation pump, one pressure expansion tank and steam regulating valves. One to three additional water loops, each with a water circulating pump and temperature regulation valves, can be included. The GS HW unit is completely assembled.

#### FLEXIBILITY

The main cycle has a high heating capacity resulting in a flexible HW unit which can be used for many different heating purposes. The secondary loops can be supplied with individual water temperatures depending on process requirements.

#### NOMINAL CAPACITY

The heat capacity of the main cycle is 245 kW. The heat capacity of the secondary loops depends on process requirements. Working pressure of the main water loop is 1.5 bar. The water temperature is maximum 90°C.

#### CERTIFICATION

The construction is in accordance with the European Pressure Equipment Directive (PED) 2014/68/EU. Other certifications can be delivered on request.



#### MATERIALS

Water contacting parts are made in stainless steel AISI 304.

#### OPTIONS

A water circulation pump in each secondary loop with a flow rate of 25 m<sup>3</sup>/h is available when high flow rates and low  $\Delta T$  are required.

#### ADDITIONAL TECHNICAL INFORMATION

Heating medium: 3.5 - 6 bar saturated steam for the first hot water loop. Pressurized air of 6 bar for instruments.

GS HW UNIT	WITH ONE LOOP	WITH TWO LOOPS	WITH TREE LOOPS	WITH FOUR LOOPS
NOMINAL CAPACITY [KG/H]	245	245	245	245
CONTROLLABLE TEMPERATURES [°C]	1	2	3	4
MAX. TEMPERATURES [°C]	90	90	90	90
STEAM FLOW AT 3.5 BAR [KG/H]	414	414	414	414
WATER CIRCULATION PUMP MAIN CYCLE - MOTOR [KW]	1.5	1.5	1.5	1.5
WATER CIRCULATION PUMP MAIN CYCLE - FLOW RATE [M <sup>3</sup> /H]	30	30	30	30
WATER CIRCULATION PUMP MAIN CYCLE - MAX. WORKING PRESSURE [BAR]	0.95	0.95	0.95	0.95
PUMP OPTION FOR SECONDARY LOOPS - MOTOR [kW]		1.1 OR 1.5	1.1 OR 1.5	1.1 OR 1.5
PUMP OPTION FOR SECONDARY LOOPS - FLOW RATE [M <sup>3</sup> /H]		15 OR 25	15 OR 25	15 OR 25
PUMP OPTION FOR SECONDARY LOOPS - MAX. WORKING PRESSURE [BAR]		1.1 OR 1.3	1.1 OR 1.3	1.1 OR 1.3
LOOP CONNECTION ISO 2037 [MM]	51x1.2	51x1.2	51x1.2	51x1.2
DIMENSION WxLxH [CM]*	88x194x214	88x218x214	88x253x214	88x288x214
MACHINE WEIGHT [KG]	473	533	601	673

\* Approximately

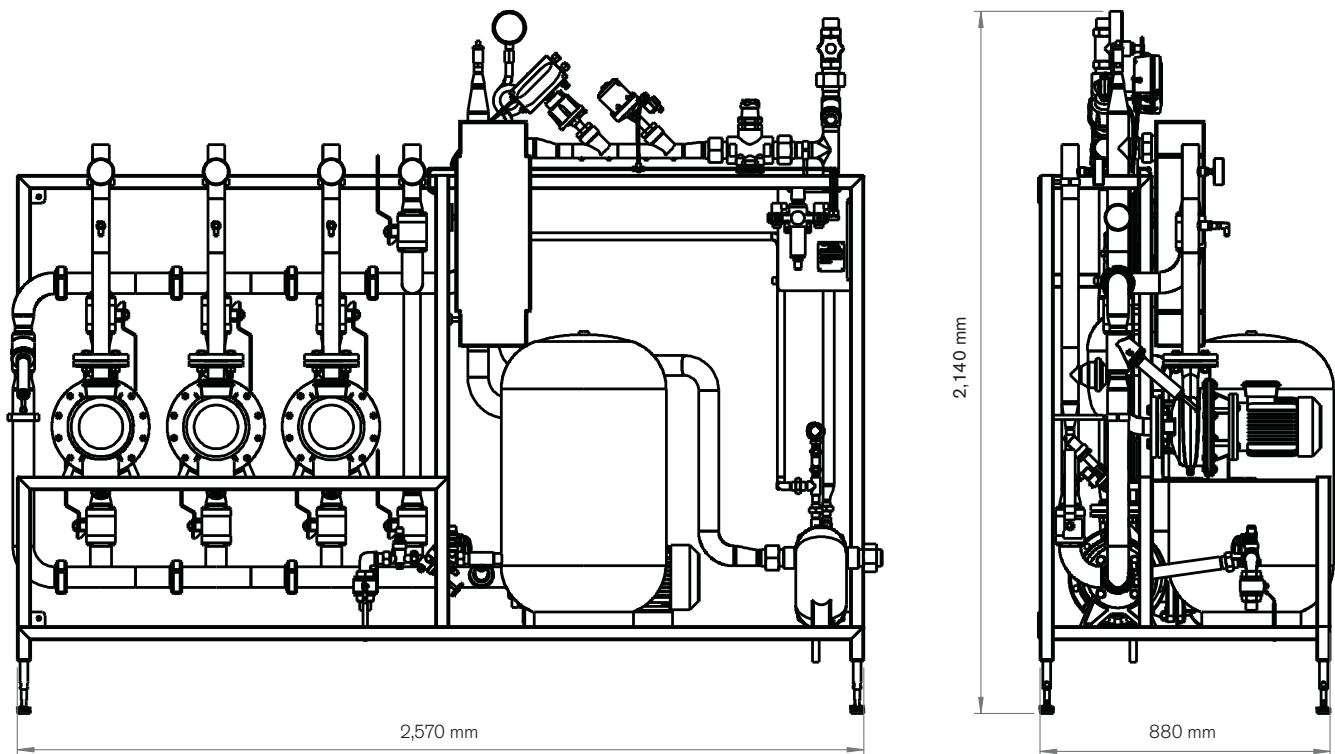

GS hot water unit with four loops

**SPXFLOW**

SPX FLOW Oestmarken 7, 2860 Soeborg, Denmark

P: +45 70 278 222, F: +45 70 278 223

E: gs.dk.sales@spxflow.com · www.spxflow.com

SPX FLOW reserves the right to incorporate our latest design and material changes without notice or obligation. Design features, materials of construction and dimensional data, as described in this bulletin, are provided for your information only and should not be relied upon unless confirmed in writing. Please contact your local sales representative for product availability in your region. For more information visit [www.spxflow.com](http://www.spxflow.com). The green ">" is a trademark of SPX FLOW, Inc.

GS-609-GB VERSION 03/2016 ISSUED 01/2017

COPYRIGHT © 2016 SPX FLOW, Inc.